

Universal Thermo Switch Installation Guide.



Please Read These Instructions Carefully Before Commencing Installation.

**This universal thermo switch is to be used in conjunction with a suitable cooling fan only,
Please ensure that you have purchased the correct product for your vehicle.**

**If You Are Uncertain About Any Aspect Of Installation,
Please Seek The Advice Of A Qualified Auto electrician.**

For DIY Installation You Will Need The Following:

- Thermo Switch
- Basic Understanding Of Electrical & Mechanical Operations
- Screw Driver Set
- Automotive Crimping Tool
- Automotive Wire Cutters

Step 1.

**Before Commencing Installation Ensure That You Have Everything Required For
Installation, And That Your Thermo Kit Contains All Of The Required Components: -**

- Thermo Switch x 1
- Knob For Adjustable Shaft x 1
- Mounting Screws x 6
- Electrical Wire x 1
- Wire Connectors x 4
- Mounting Bracket x 1
- Rubber Probe Seal x 1
- 12v Relay (with bracket) x 1

PLEASE NOTE

Whilst every care has been taken to ensure that these are accurate we (the supplier)
cannot be held responsible for the information contained herein.

Please note that product specifications and part numbers may change from time to time in line with our policy of continual
improvement. We therefore reserve the right to alter product specifications without notice.

All sections of this leaflet are the (C)opyright of CCL 1998-2010
All Rights Reserved.
E & OE

Step 2.

Check That Your Engine And Radiator Are Cold.

IMPORTANT NOTE

NEVER ATTEMPT TO REMOVE THE RADIATOR CAP OR HOSE ON A HOT OR EVEN WARM RADIATOR / COOLING SYSTEM.

- Once you have ascertained that the system is cold, remove the top radiator hose. Use caution when doing this to ensure that you do not damage the radiator.

Step 3.

Mounting The Thermo Switch.

- Place the copper probe inside the top of the radiator hose, and mount the switch in a suitable position nearby, ensuring not to overstretch the copper cable on the probe and that it is accessible for adjustment.
- Carefully refit the top hose using the rubber probe seal to ensure a tight seal where the copper probe enters the top hose, and tighten the hose clamp.
- Ensure that the copper probe is appx 3cm down the top hose when refitting the top hose and do not use excessive force to prevent any damage to the inlet pipe on the radiator.

Step 4.

Refilling The System.

- Top up the radiator / cooling system with water and/or coolant in-line with the vehicle manufacturers specification.
Run the engine and carefully check the top hose for leaks.
- If there are any leaks at all, DO NOT drive the vehicle, but instead repeat steps 2, 3 & 4 again, using automotive silicone if required to ensure a tight seal. (if silicone is used, do not start the engine to test the system until the silicone is fully cured).
- If there are no leaks (or when the leaks have been repaired) proceed to step 5.

Step 5.

- Connect your thermo switch inline with the diagram on the opposite page.

Step 6.

- Start the engine and run it until it reaches the required operating temperature. Watch the temperature gauge in your vehicle carefully, once it reaches the required temperature, proceed to step 7.

IMPORTANT NOTE

IF YOUR TEMPERATURE GAUGE DOES NOT WORK DO NOT PROCEED TO STEP 7 UNTIL IT HAS BEEN REPAIRED. IF YOUR ENGINE OVERHEATS IT MAY CAUSE SERIOUS DAMAGE.

Step 7.

- Turn the adjustable shaft on the thermo switch fully on, and then slowly reverse it until the fan(s) turns on. The fan(s) and thermo switch should now be set for cooling of a motor vehicle during normal road use.

Wiring Instructions

Follow the terminal connection guide and schematic diagrams below and ensure that all electrical connections are secure and insulated.

Relay Connections

- Terminal 30: 12 Volt Power Supply (Vehicle Battery). **THIS POWER SUPPLY MUST BE FUSED.**
Terminal 85: Earth. This Must Be A Suitable Clean, Rust And Paint Free Earth Contact.
Terminal 86: 12 Volt Power Supply, Which Must Only Be Active When The Vehicle Ignition Is Switched On.
Terminal 87: Power Out, To Thermo Switch.

Thermo Switch Connections

- Terminal 1: Connect To Pin 87 Of Relay (this pin could also be identified as C, 5, or C1).
Terminal 4: Connect To The Positive Wire Of The Radiator Fan.
Terminal 2: Not Used

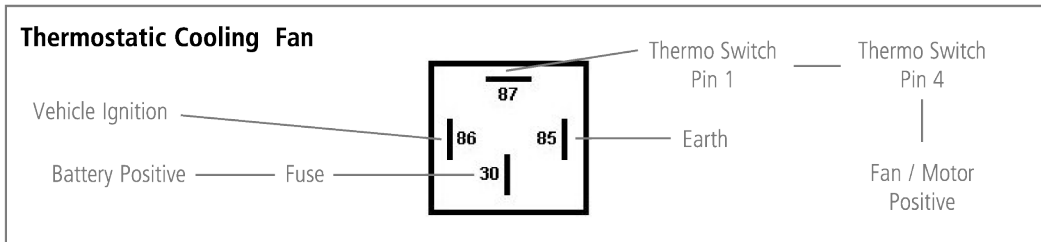

Condensor / Thermostatic Fan

PLEASE NOTE:

An additional relay is required for this setup

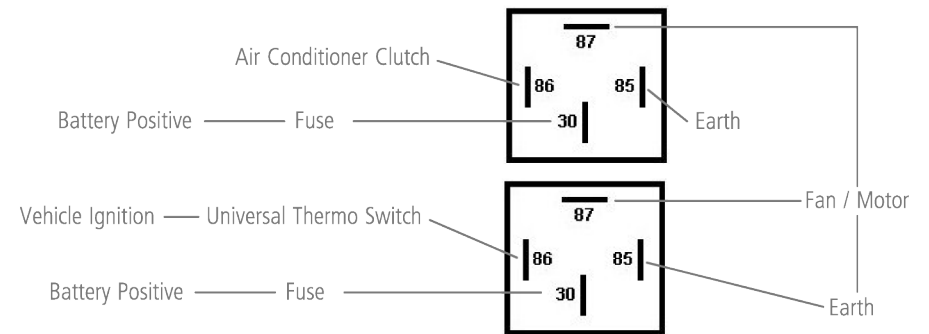

Condensor Fan

